

# Gesture Recognition using Sensors for Physically Disabled Patients

[1] [2] [3] [4] [5]  
Arun S.Tigadi , Sneha Reddy, Ashwini Singadi, Ayisha Nadaf, Soumyashree A

[1] Assistant Professor, [2][3][4][5] UG Students

[1][2][3][4][5] Department of Electronics and Communication Engineering Dr M S.Sheshgiri College of Engineering and Technology Udyambag,Belagavi

---

**Abstract:** - In Today's world many people are suffering from Physical disabilities and most of the physically disabled patients dependent on care takers. A physical disability is a limitation on a person's physical functioning, mobility or stamina. In extreme cases, the patient may be speech impaired which makes it difficult for him to communicate with others and to express his needs. Providing solution to these inabilities is the prime motive of this proposed work. The physically disabled persons require special assistance from care takers or other persons to lead their normal life and even at home it is not convenient for them to control the home appliances according to their wish. Apart from this, it is also difficult to continuously monitor the health of the patient. The aim of our project is to design and implement the device multi sensor- gesture-gestured based home automation system and develop MEMS based wheel chair control which is useful to physically disabled person ,with his hand movement or his hand gesture recognition using MEMS technology he can control the action of wheel chair . we used an IR sensor as wireless switches for control of home appliance using an RF modules

## I. Introduction

In this project A MEMS accelerometer and an IR sensor based home automation system is designed for physically challenged and partially paralyzed persons. The system comprises accelerometer, microcontroller, RF transmitter and receiver and the communication are through RF signals. The accelerometer senses the hand gestures and signals are transmitted to wheel chair section through microcontroller. The IR sensors are used as switches to control the different home appliance signals are transmitted to receiver section through RF transmitter. the proposed work is as shown in figure1 and figure2 the accelerometer output voltages are given to the comparator circuit then the different output voltages are taken by varying the reference voltage of the comparator to move the wheel chair in different direction .the home appliance are controlled through IR sensor and RF module .the IR sensors are used as wireless switches for home appliance control .in this project we have used four IR transmitter and receiver to control four different home appliance like fan ,bulb, mobile charger, etc. in our project the optocoupler is used to switch the IR receiver outputs to drive the four different home appliances

## II .PROPOSED MODEL

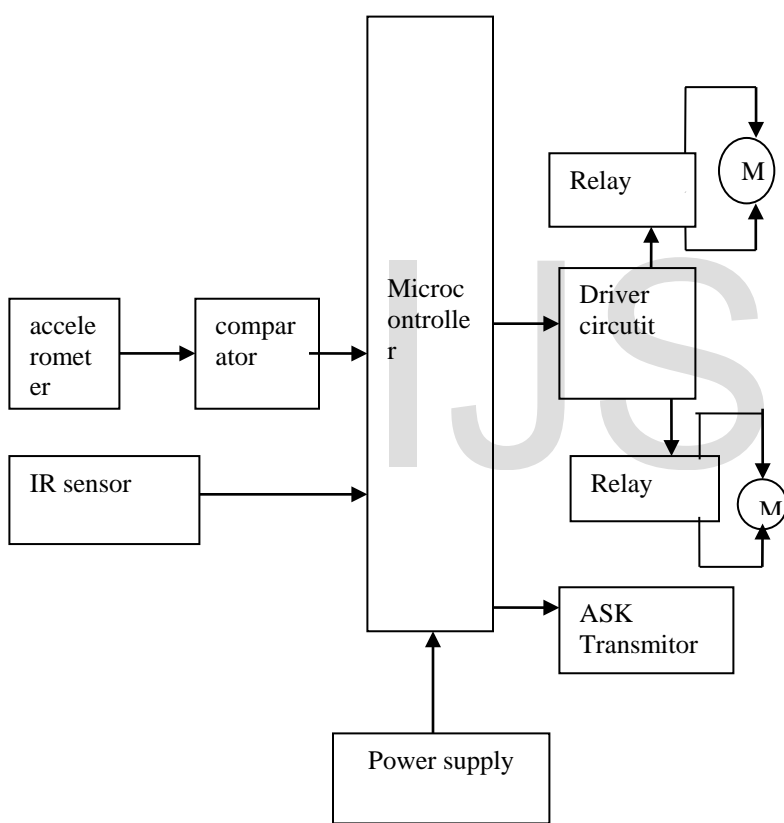

Figure 1.the transmitter block diagram

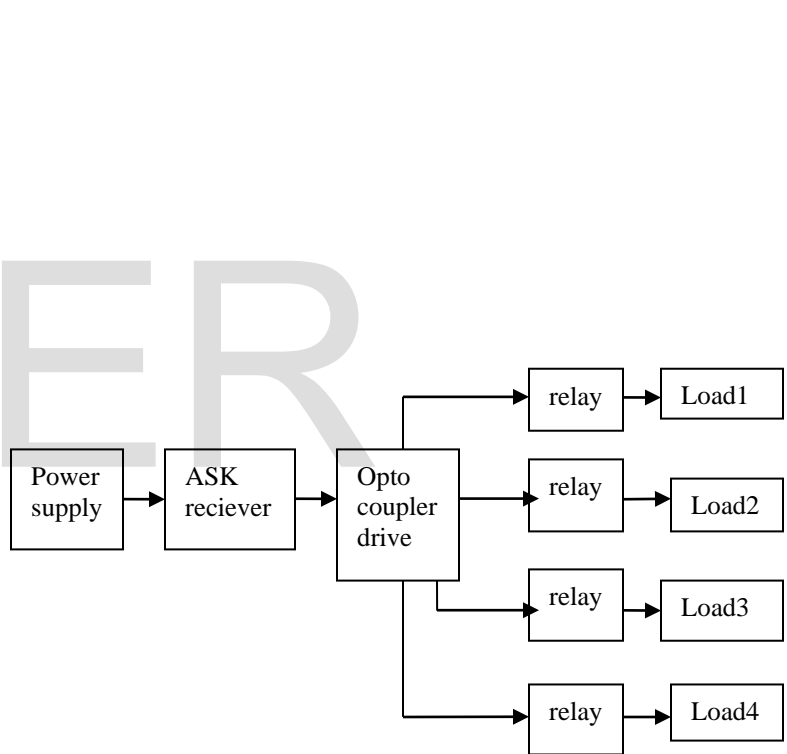

Figure 2.the receiver block diagram

### III. Materials and Method

#### MEMS sensor:

#### ACCELEROMETER:

An accelerometer is a device that measures proper acceleration. The proper acceleration measured by an accelerometer is not necessarily the coordinate acceleration (rate of change of velocity). Instead, the accelerometer sees the acceleration associated with the phenomenon of weight experienced by any test mass at rest in the frame of reference of the accelerometer device.

An accelerometer is a one type of sensor and it gives an analog data while moving in the direction of X, Y and Z. These directions depend on the type of sensor. The diagram of accelerometer is shown in fig 3. This sensor consists of arrow directions, if we tilt the sensor in one direction, then the data at the particular pin will change in the form of analog. In our project the ADXL335 accelerometer is used to detect the hand gesture, depending on different gesture the control of motor is done to activate the wheel chair. the o/p of this sensor is fed to the comparator. four LEDs are provided to indicate wheelchair directions that is front, back, left and right.

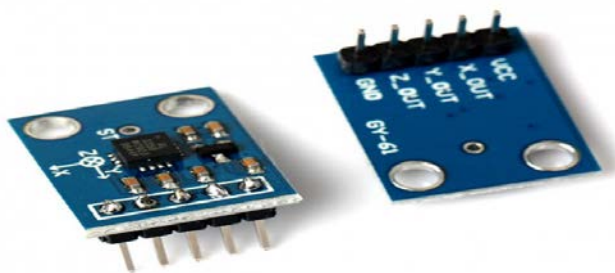

Figure 3. ADXL335 Accelerometer sensor

Table 1. Accelerometer connection

Pin number	Connection
Pin 1	VDD pin is used to give supply to this pin
Pin 2	GND pin is connected to the ground for the purpose of biasing
Pin 3	X pin will receive the data in the X direction
Pin 4	Y pin will receive the data in the Y direction
Pin 5	Z pin will receive the data in the Z direction
Pin 6	ST pin is used to adjust the sensitivity of the accelerometer 1.5g or 2.5g or 4g

#### COMPARATOR

LM 339 is a comparator IC having 4 built in comparators. A comparator rotates a signal between digital and analog domain. First of all, it compares the 2 different inputs applied at the input terminal and then gives the output in digital form in order to indicate which of the input applied has a larger amplitude.

**AT89S52:** The AT89S52 is a low-power, high-performance CMOS 8-bit microcontroller with 8K bytes of in-system programmable Flash memory. The device is manufactured using Atmel's high-density nonvolatile memory technology and is compatible with the industry-standard 80C51 instruction set and pin out. The on-chip Flash allows the program memory to be reprogrammed in-system or by a conventional nonvolatile memory programmer. By combining a versatile 8-bit CPU with in-system programmable Flash on a monolithic chip, the Atmel AT89S52 is a powerful microcontroller, which provides a highly flexible and cost-effective solution to

many, embedded control applications. The AT89S52 provides the following standard features: 8K bytes of Flash, 256 bytes of RAM, 32 I/O lines, Watchdog timer, two data pointers, three 16-bit timer/counters, a six-vector two-level interrupt architecture, a full duplex serial port, on-chip oscillator, and clock circuitry. In addition, the AT89S52 is designed with static logic for operation down to zero frequency and supports two software selectable power saving modes. The Idle Mode stops the CPU while allowing the RAM, timer/counters, serial port, and interrupt system to continue functioning. The Power-down mode saves the RAM contents but freezes the oscillator, disabling all other chip functions until the next interrupt. In our project the 89s52 microcontroller is used since it is inexpensive and provides sufficient ports for different applications to be connected to it. The microcontroller is programmed using Keil uVision in assembly C language. The microcontroller used in the wheel chair system provides necessary commands to the driver circuit to control the direction of the wheel chair as per the physically disabled person's needs. The output values of the accelerometer are fed to a comparator that the comparator converts analog signals into a form that is suitable to the microcontroller. The microcontroller is programmed to drive the driver part of the wheelchair system. The microcontroller in the home appliance control part is used to send data from the IR transmitter module.

## Wireless Transmitter and Receiver using RF Modules

Communication over Radio Frequency has many advantages as it doesn't require a line of sight connection between the transmitter and receiver as in the case of Infrared communication.

The range of RF communication is very high when compared to IR communication. In this project, a wireless

transmitter and receiver system using RF modules (RF Transmitter and RF Receiver) is implemented.

An RF Transmitter and Receiver pair is used for wireless communication. The wireless data transmission is done using 433 MHz Radio Frequency signals that are modulated using Amplitude Shift Keying (ASK) Modulation technique. In order to implement the wireless transmitter and receiver, we use an encoder IC HT12E as shown in fig 4 and a decoder IC HT12D as shown in fig 5. The circuit is divided into transmitter and receiver sections. The transmitter section consists of an RF Transmitter, HT12E encoder IC. The receiver section consists of RF Receiver, HT12D Decoder IC and four LEDs. An extra LED is connected to VT (Valid Transmission) pin of the decoder IC. This is used to indicate a successful transmission of data. A 1 MΩ resistor is connected between the oscillator terminals of the encoder IC. This is to enable the oscillator. Similarly, a 56 KΩ resistor is connected between the oscillator pins of the decoder IC.

### HT12E

It is an encoder IC that converts the 4-bit parallel data from the 4 data pins into serial data in order to transmit over RF link using transmitter.

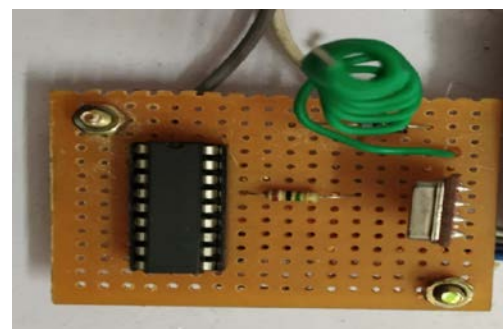

Figure 4. RF Transmitter with Encoder

### HT12D

It is a decoder IC that converts the serial data received by the RF Receiver into 4-bit parallel data and drives the LEDs accordingly.

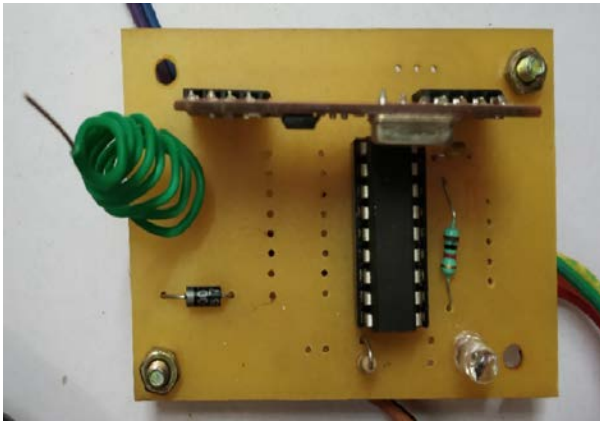

Figure 5.RF Receiver with Decoder

## Working

The transmitter and receiver sections are placed at a distance of at least 20 meters. In order to show the working of wireless communication between transmitter and receiver, 4 RELAY at receiver side are controlled by 4 IR SENSOR at transmitter section. This is shown in figure 5

The HT12E encoder IC converts the 4-bit data from the 4 data pins that are connected to sensor into serial data. This serial data is sent to RF transmitter. The RF transmitter transmits this serial data using radio signals.

At the receiver side, the RF receiver receives the serial data. This serial data is sent to HT12D decoder IC which converts into 4 bit parallel data.

The 4 data pins of decoder are connected to relays. According to the sensor, the home appliances can be turned ON or OFF.

## IV.ADVANTAGES

- It helps for physically challenged people.

- It is self controlled moving vehicle.
- No need for cabling because of wireless
- No need to carry separate remote or any other controlling unit

## V.CONCLUSION

In this project we have designed a wireless home automation control system with accelerometer based wheelchair it reduces the risk of physical disabled person. and this project is helpful to provide independent work to be carried out by the physically disabled person which reduces dependency on care taker .

## References

- 1.wearable multi-sensor gesture recognition for paralysis patients A. Nelson, J. Schmandt, P. Shyamkumar, W. Wilkins, D. Lachut, S. Rollins, J. Parkerson, SENSORS, 2013 IEEE
2. MEMS based Hand Gesture Wheel Chair Movement Control for Disable Persons V Sundara Siva Kumar†, G.Ramesh† and P Nagesh
- 3.Department of Electronics & Instrumentation, Rajeev Gandhi Memorial Engineering College, Nandyal, India ( 25 May 2015, Vol.5, No.3) Sree Kavitha Engineering College Khammam, India
- 4 Abirami B, Anupriya S R, Divyarani R, Nagaraju “VACCCELEROMETER BASED HAND GESTURE CONTROLLED WHEELCHAIR” Volume 4, Issue 4 (July-Aug, 2016)
- 5.A Motion Control Method of Intelligent Wheelchair Based on Hand Gesture Recognition Tao Lu Institute of Automation Chinese Academy of Sciences Beijing, China
- 6.Design and Implementation of Home Monitoring System Using RF Technology Nidhi Gaur 1 , Shabarinath B.B 2 , 1 2 Department of Electronics and Communication Engineering 1 Assistant Professor, Amity University 2 Mtech-Embedded Systems Technology, Amity University 2013 IEEE 8th Conference on Industrial Electronics and Applications (ICIEA)
- 7.[https://en.wikipedia.org/wiki/RF\\_module](https://en.wikipedia.org/wiki/RF_module)
- 8.<https://en.wikipedia.org/wiki/Accelerometer>
9. <https://ro.wikipedia.org/wiki/AT89S52>
- 10.[https://en.wikipedia.org/wiki/Optical\\_isolator](https://en.wikipedia.org/wiki/Optical_isolator)

IJSER